

B1=B15=B18=B19=B20=B21=B25=B28=B22=B23

P1

1x C20
PLANTA
ESC 1:25

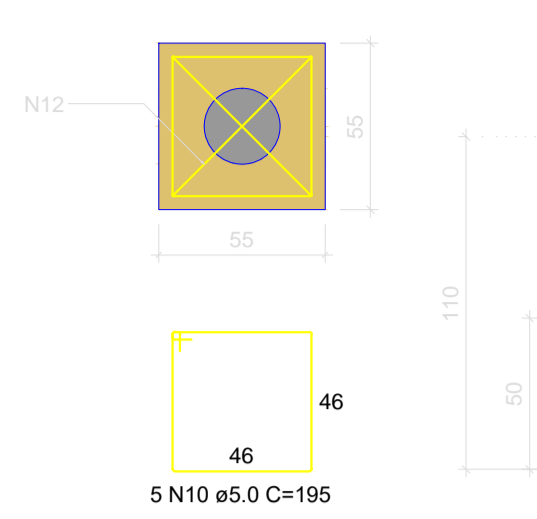

CORTE
ESC 1:25

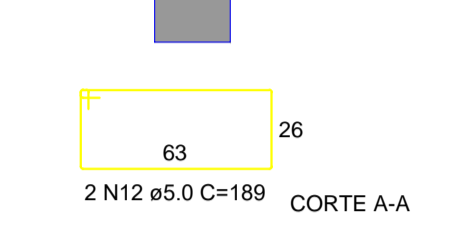
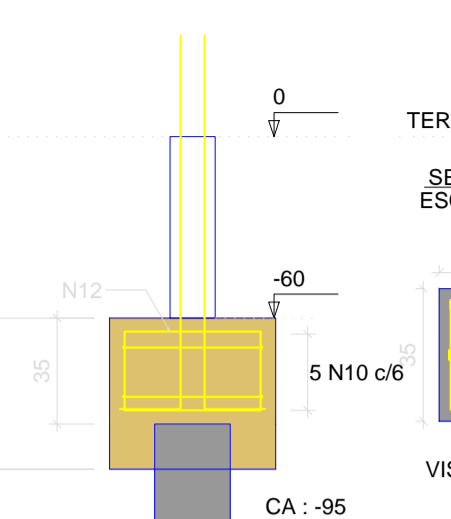

CORTE A-A
ESC 1:25

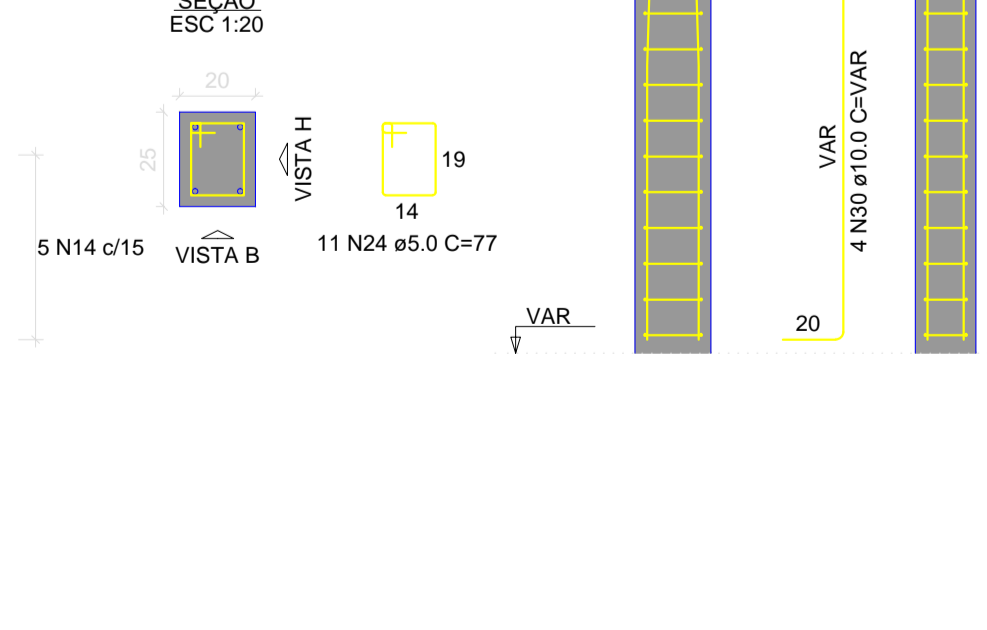
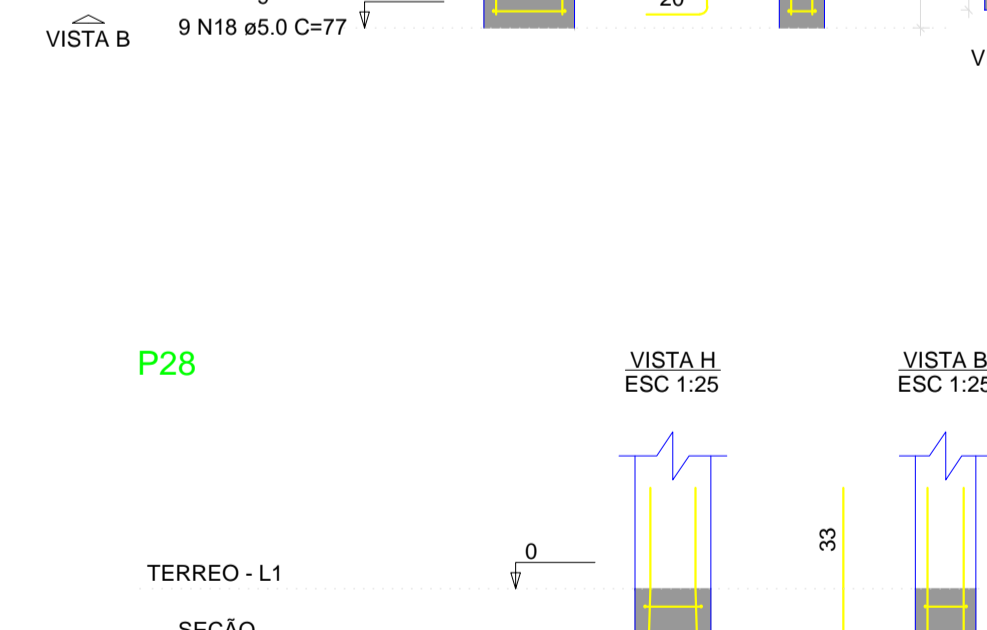
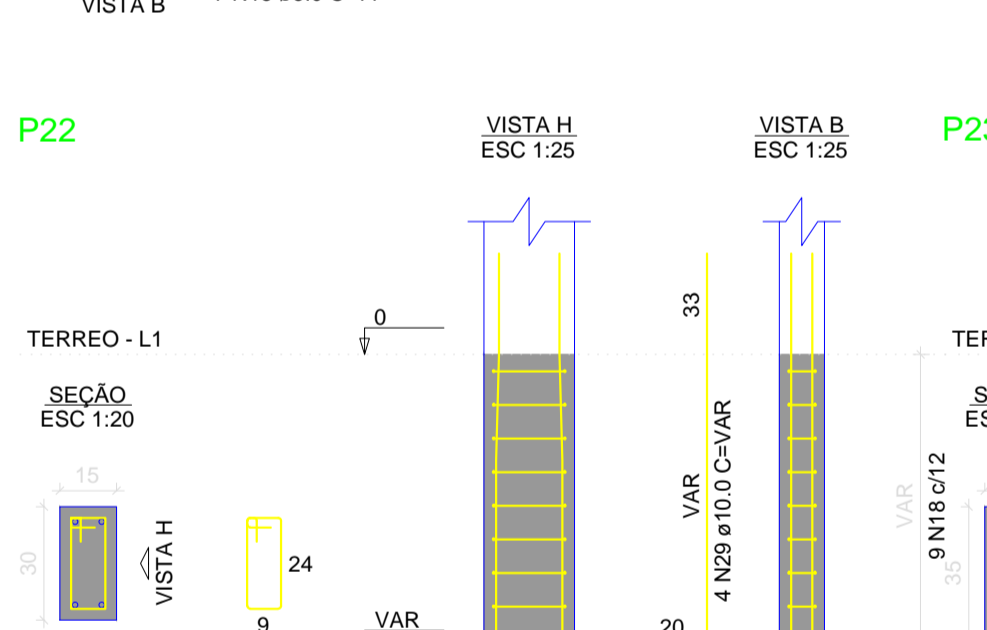
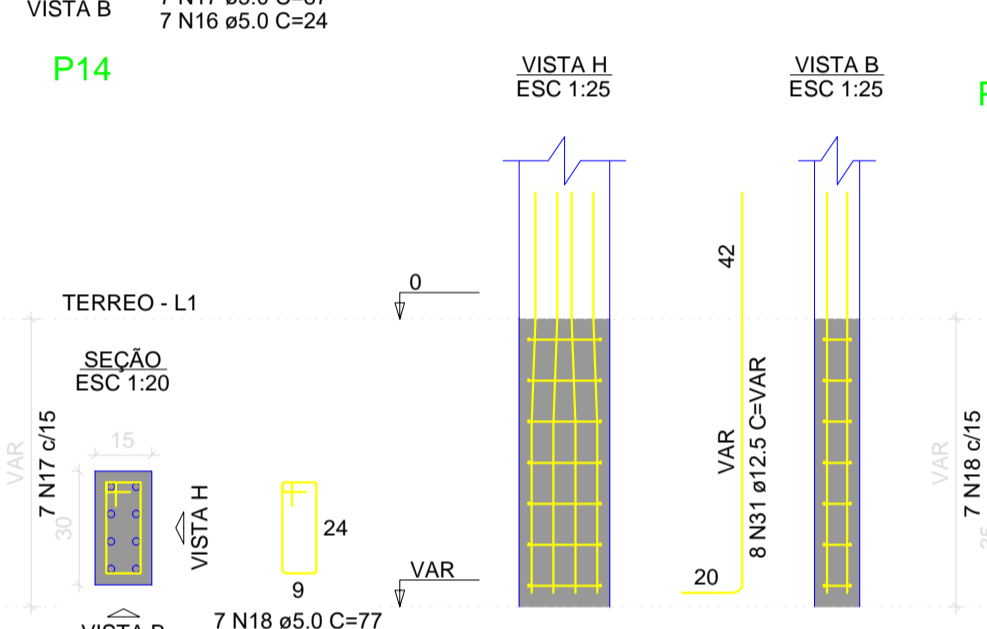
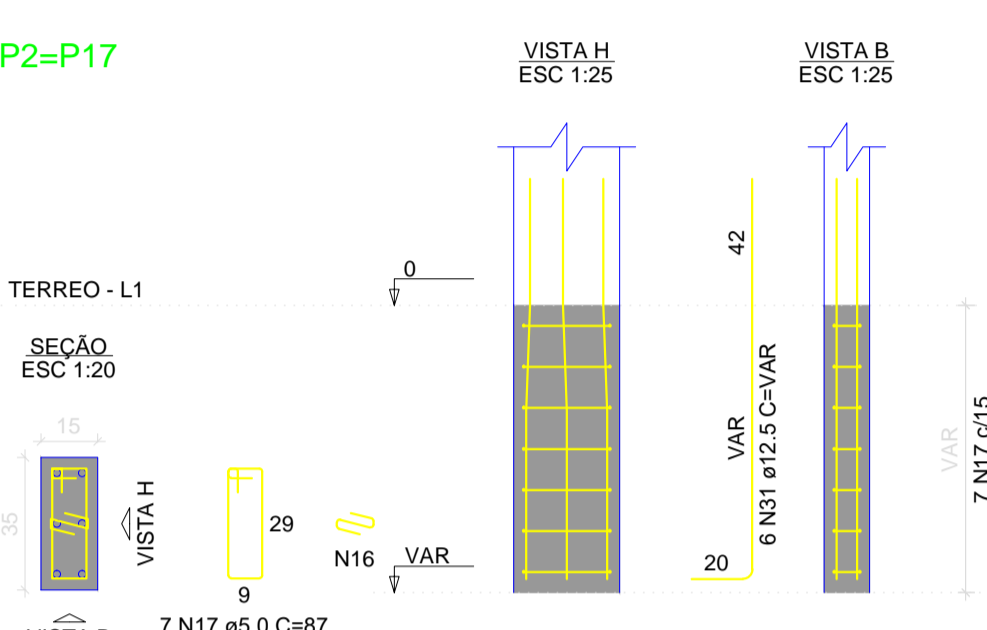

P15=P20=P21=P25

P18=P19

ESC 1:25

ESC 1:25

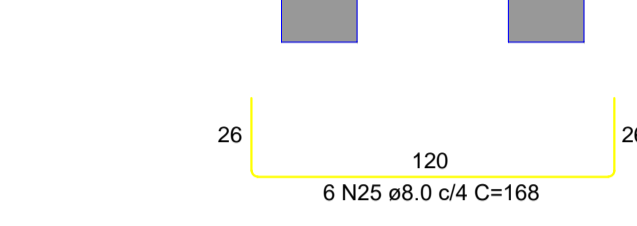
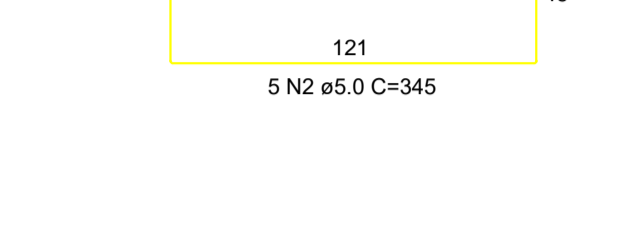
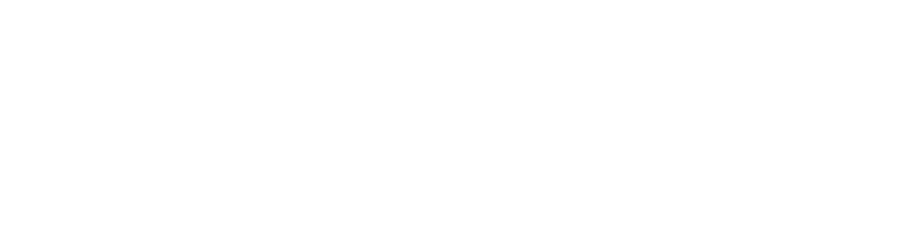
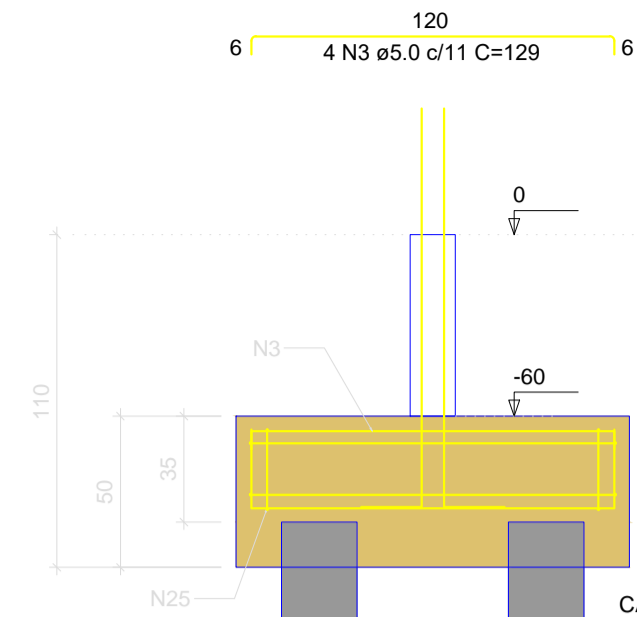
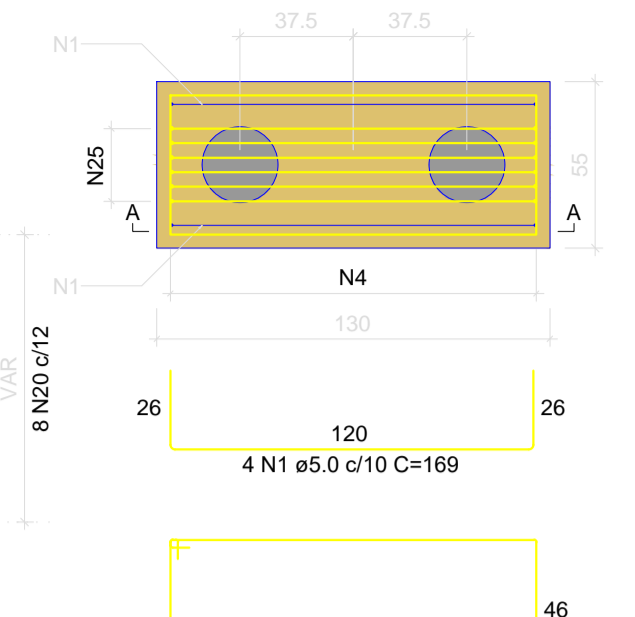
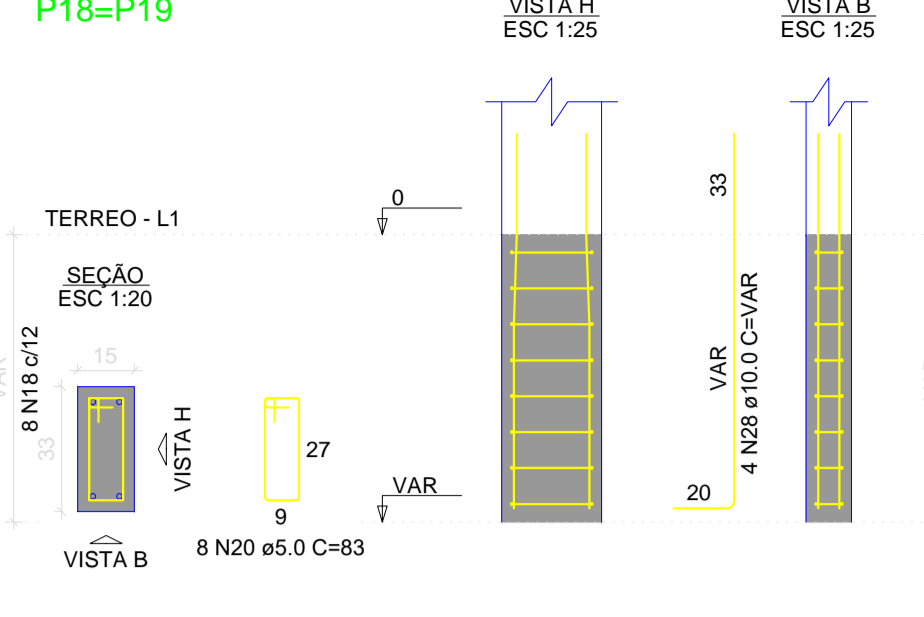
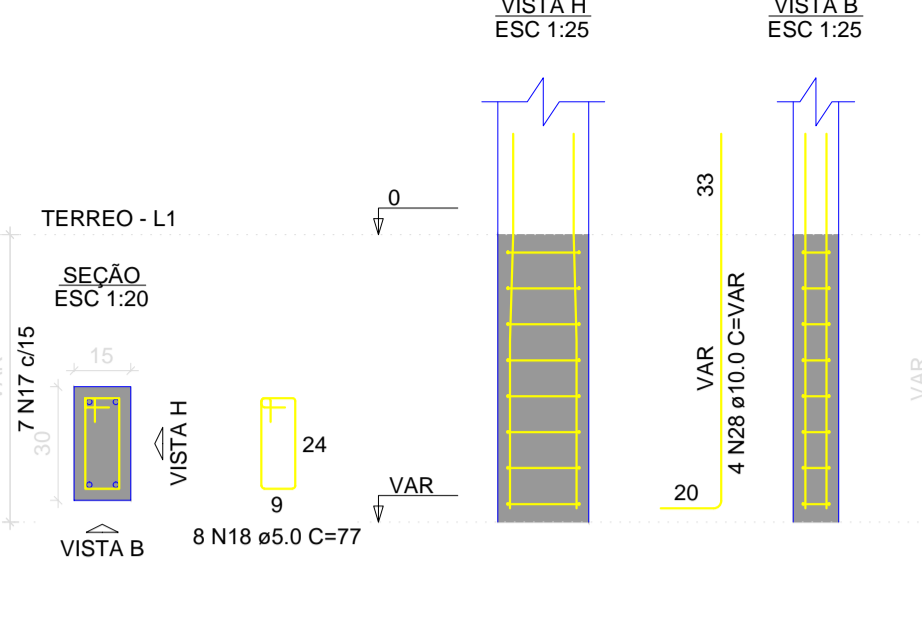

CORTE A-A
ESC 1:25

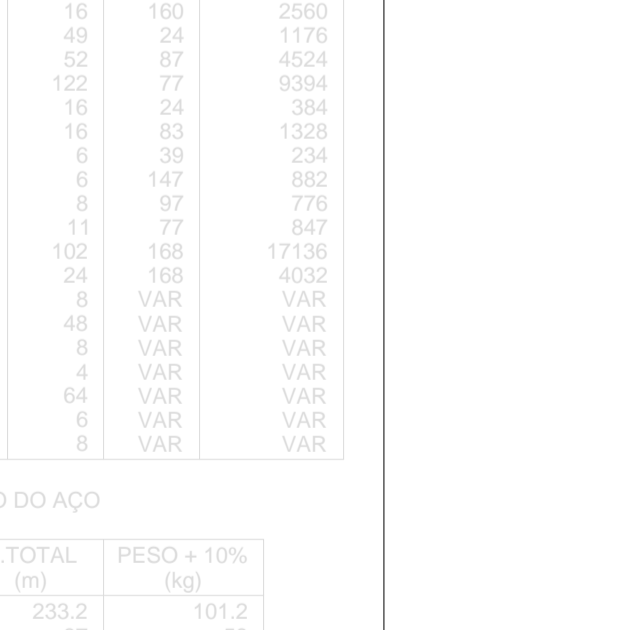
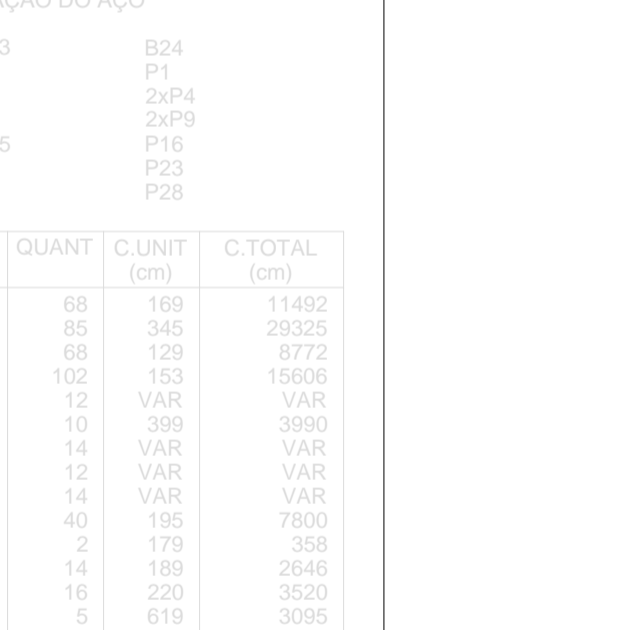
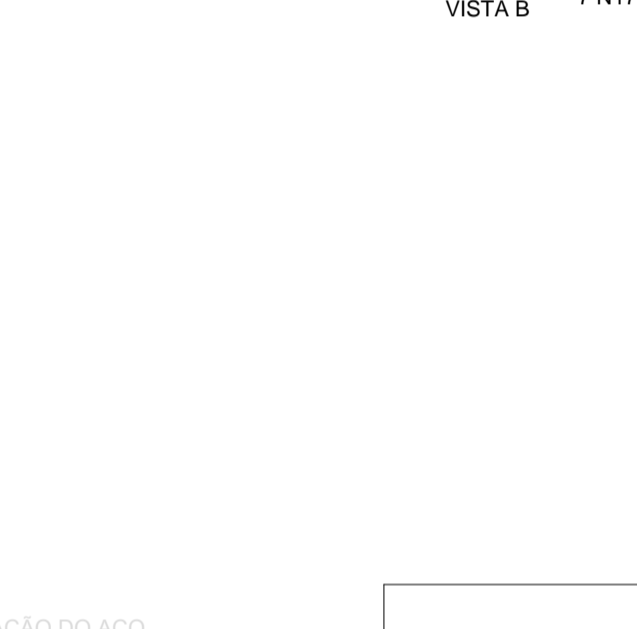
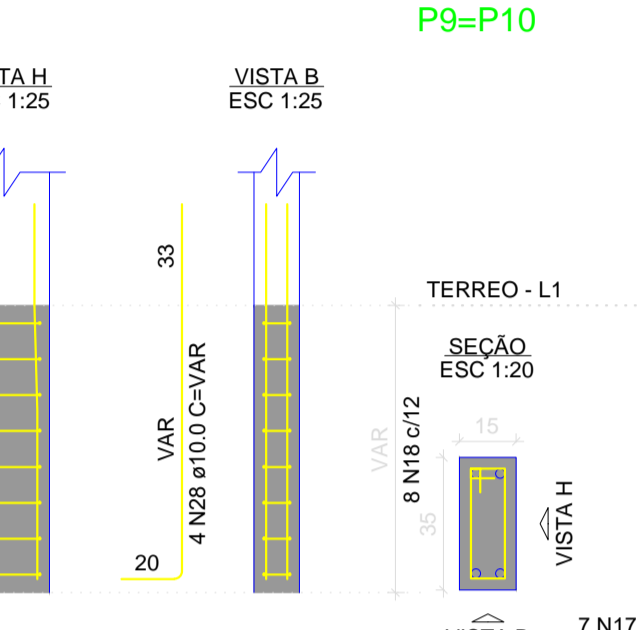
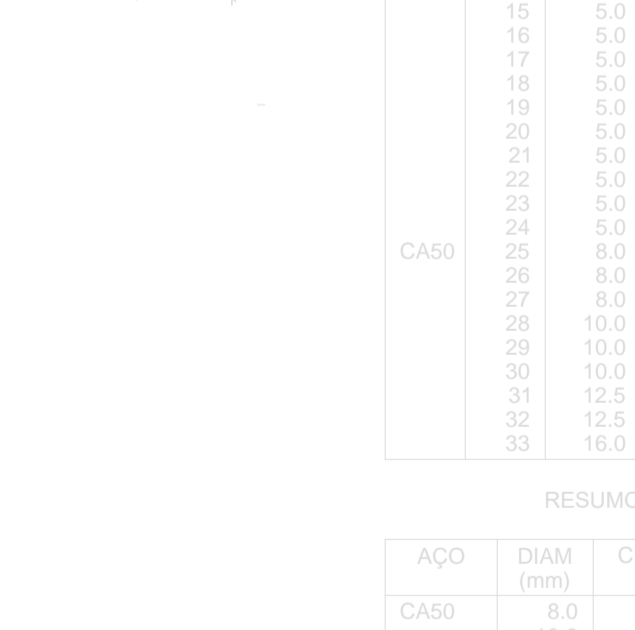
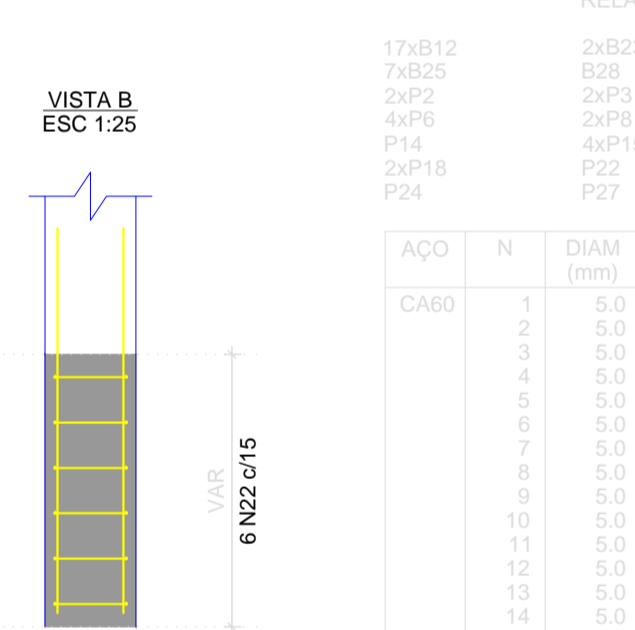
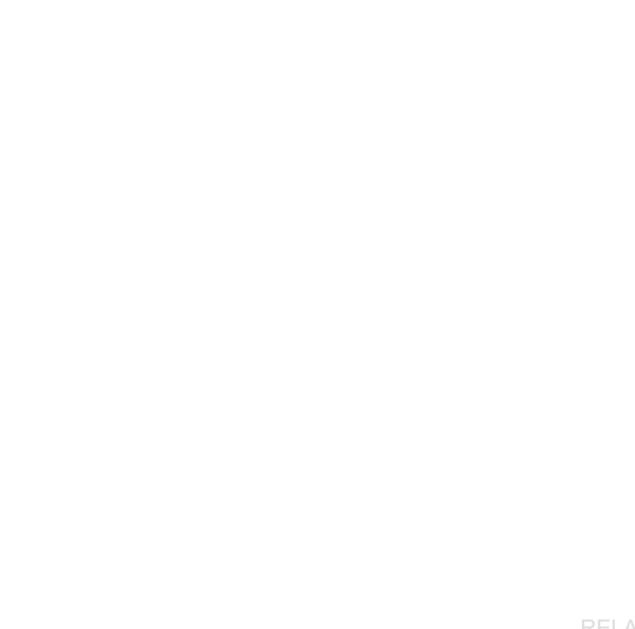
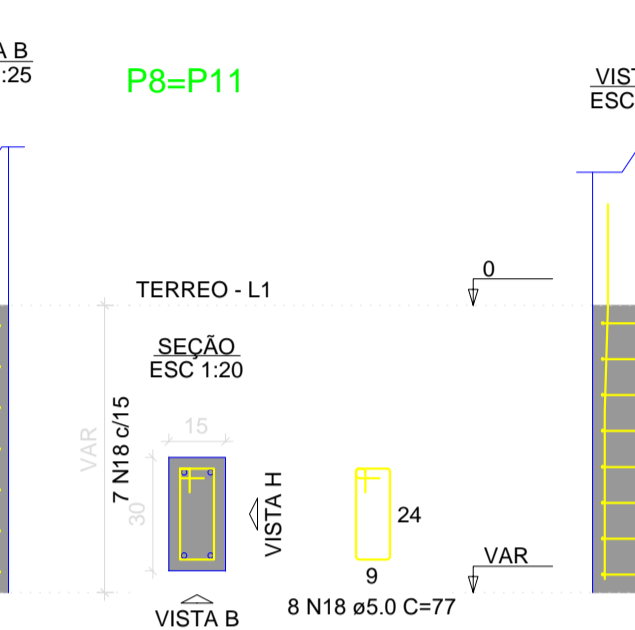
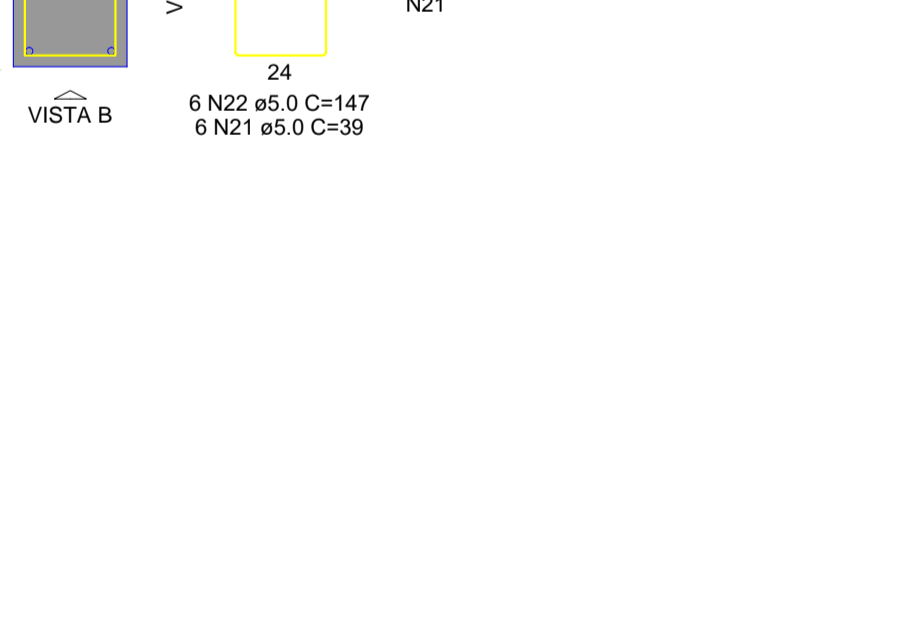
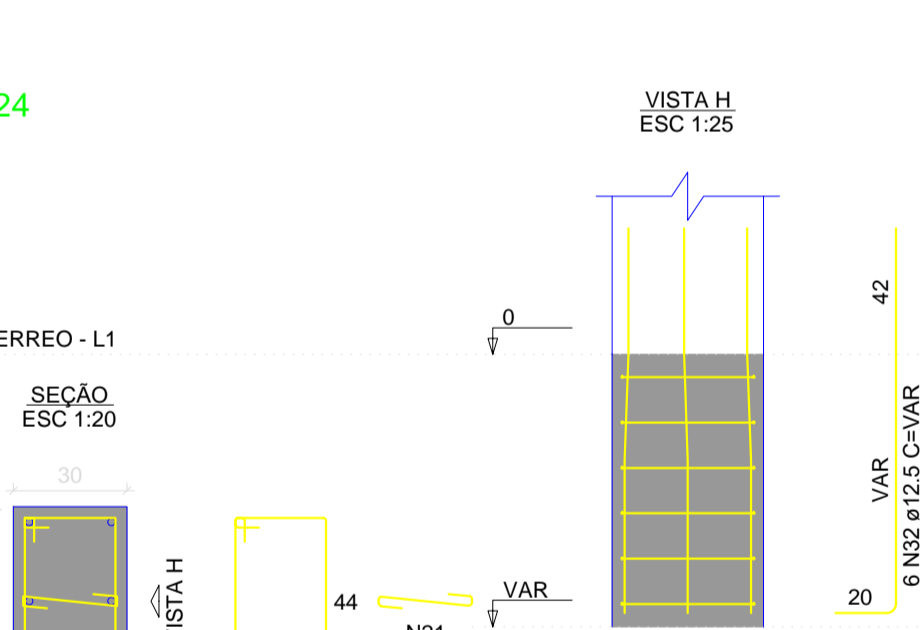
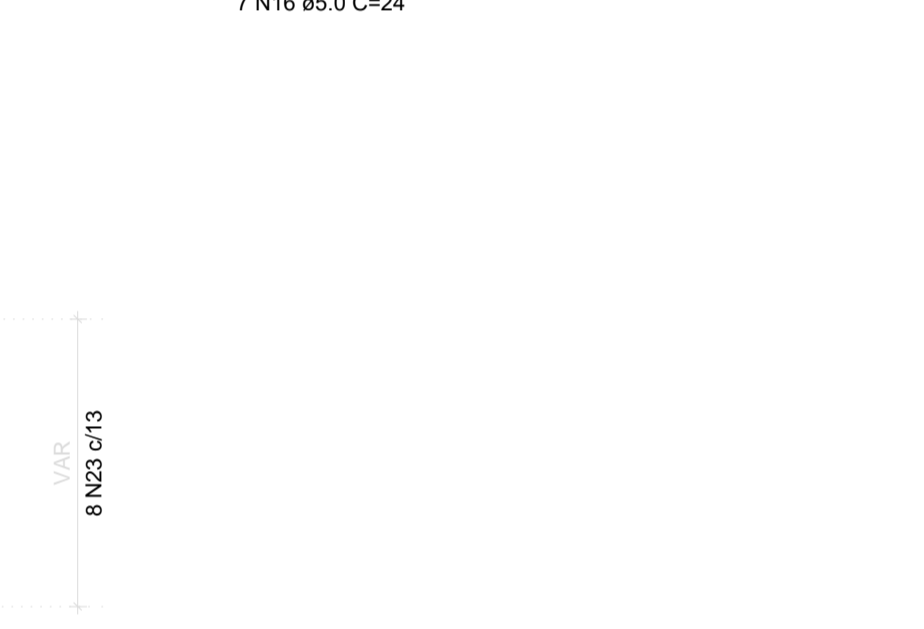
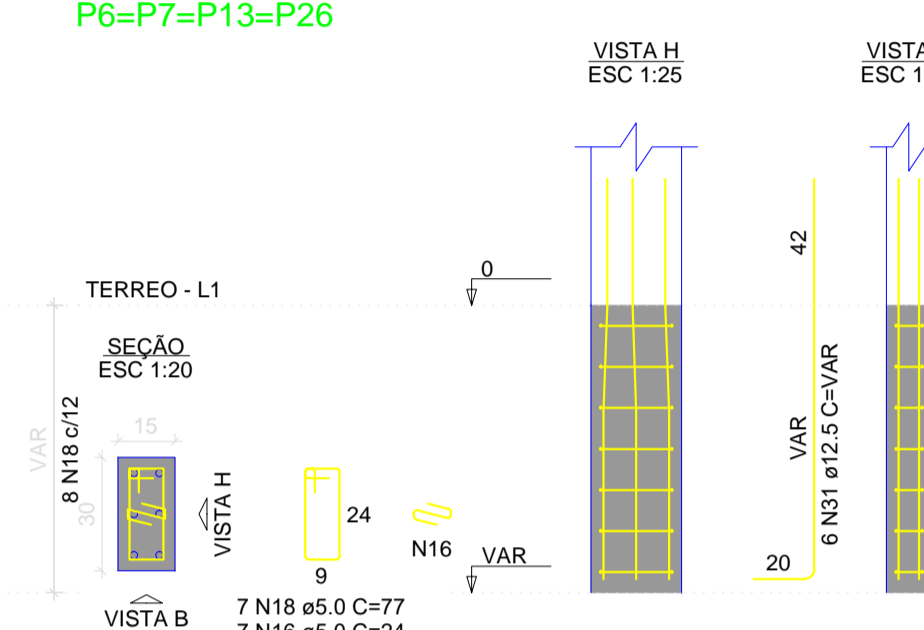
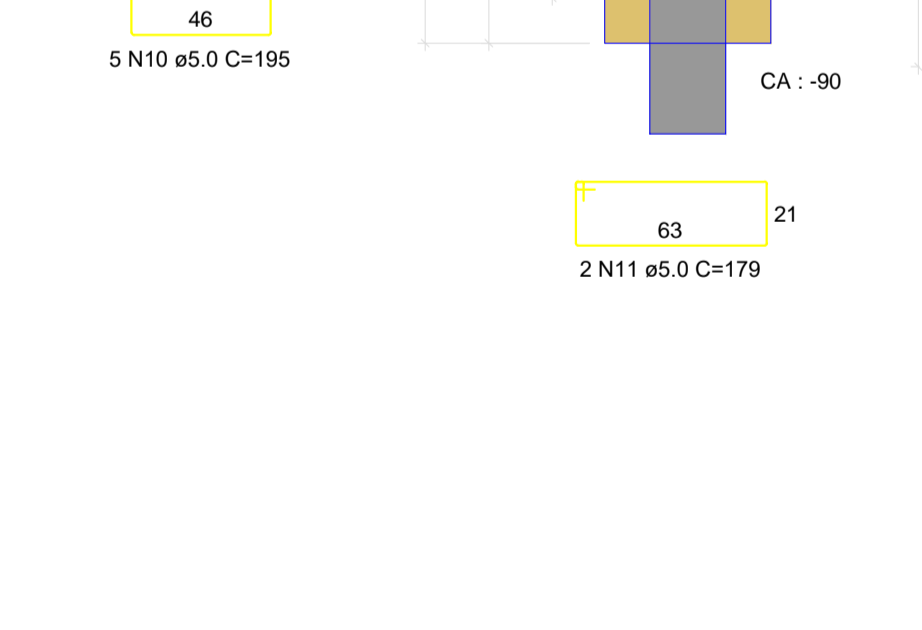
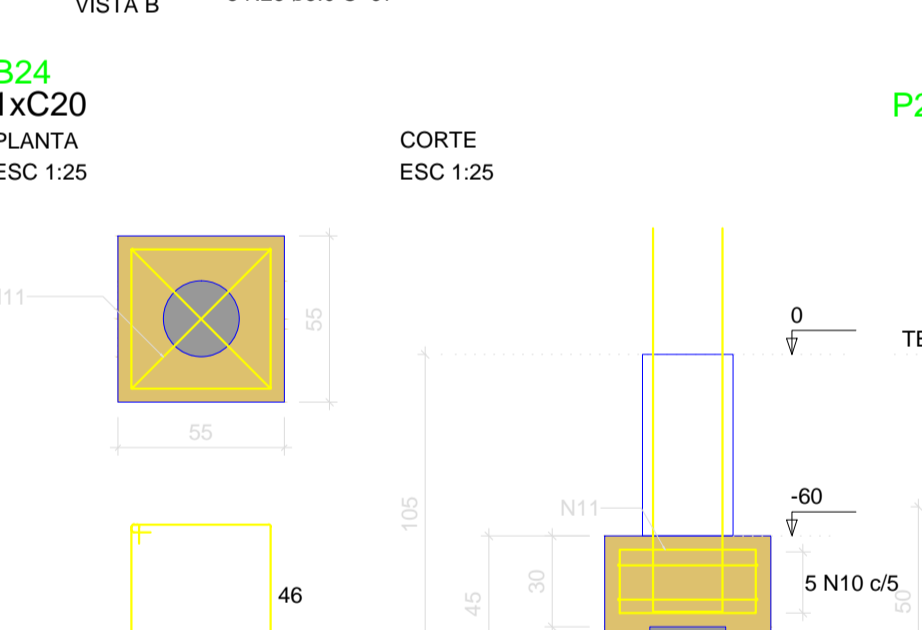
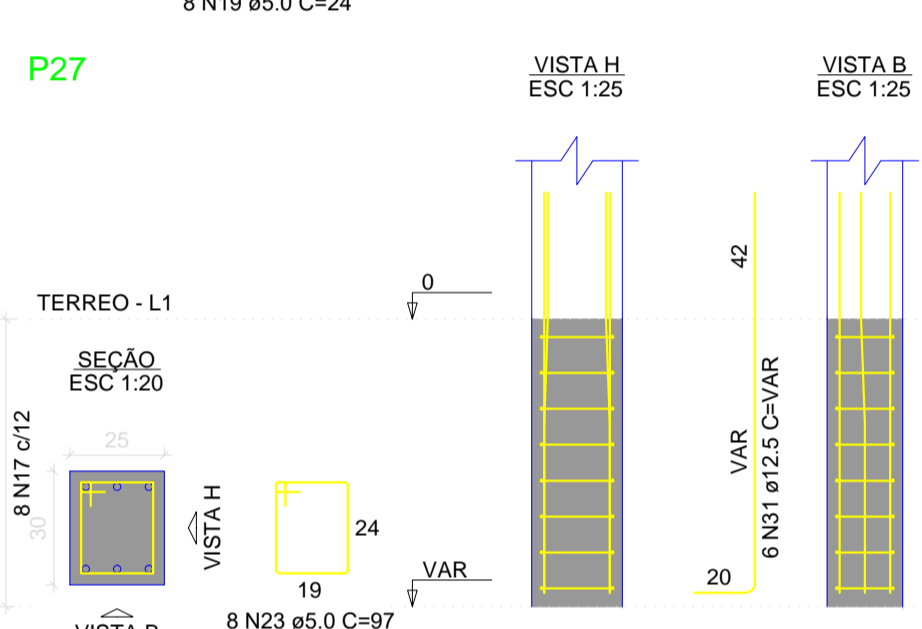
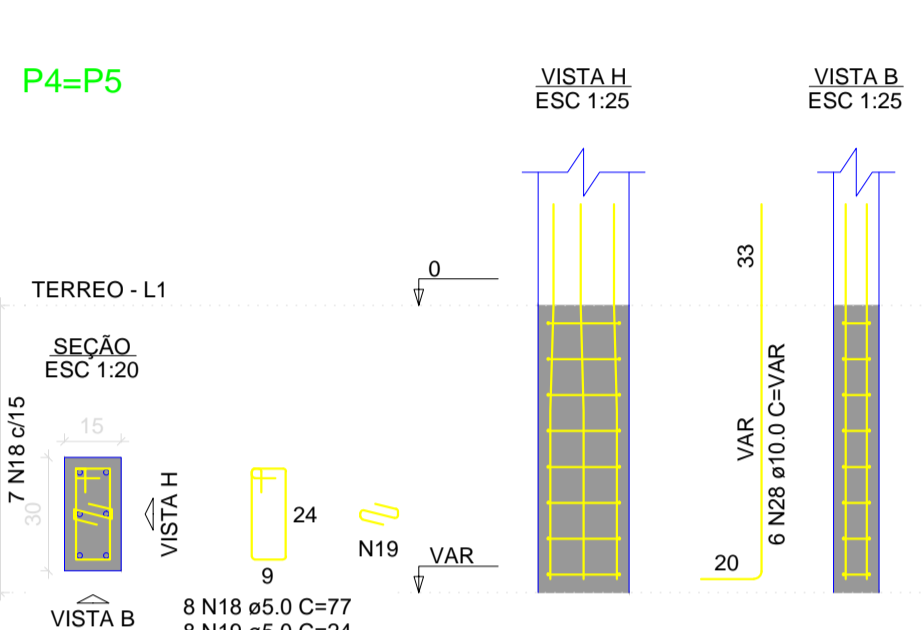

RELAÇÃO DO AÇO

AÇO	N	DIAM (mm)	QUANT	C.UNIT (cm)	C.TOTAL (cm)
CA60	1	5.0	68	169	11492
	2	5.0	85	345	29325
	3	5.0	68	129	8772
	4	5.0	102	153	15606
	5	5.0	12	VAR	VAR
	6	5.0	10	389	3990
	7	5.0	14	VAR	VAR
	8	5.0	12	VAR	VAR
	9	5.0	14	VAR	VAR
	10	5.0	40	195	7800
	11	5.0	2	179	358
	12	5.0	14	189	2646
	13	5.0	16	220	3520
	14	5.0	5	619	3095
	15	5.0	16	160	2560
	16	5.0	49	24	1176
	17	5.0	52	87	4524
	18	5.0	122	77	9394
	19	5.0	16	24	384
	20	5.0	16	83	1328
	21	5.0	6	39	234
	22	5.0	6	147	882
	23	5.0	8	97	776
	24	5.0	11	77	847
CA50	25	8.0	102	168	17136
	26	8.0	24	168	4032
	27	8.0	8	VAR	VAR
	28	10.0	48	VAR	VAR
	29	10.0	8	VAR	VAR
	30	10.0	4	VAR	VAR
	31	12.5	64	VAR	VAR
	32	12.5	6	VAR	VAR
	33	16.0	8	VAR	VAR

RESUMO DO AÇO

AÇO	DIAM (mm)	C.TOTAL (m)	PESO + 10% (kg)
CA50	8.0	233.2	101.2
	10.0	87	59
	12.5	104.7	110.9
	16.0	12.8	22.2
CA60	5.0	1166.5	197.8
PESO TOTAL (kg)			
CA50		293.4	
CA60		197.8	

Volume de concreto (C-25) = 10.32 m³
Volume de concreto (C-30) = 1.40 m³
Área de forma = 76.09 m²

PREFEITURA MUNICIPAL DE PORTO UNIÃO - SC

OBRA: REFORMA E AMPLIAÇÃO DO NEI TREM DA ALEGRIA

LOCAL DA OBRA: Rua Francisco Piluski, 258, Bairro Vice King - Porto União, SC

- DETALHES - ARMADURAS

ÁREA TOTAL: 406,61 m²

PROJETO: Estrutural

FOLHA: ESTR 05/08

RESPONSÁVEL TÉCNICO DE PROJETOS: Vinicius André Makiak
Engenheiro Civil - CREA-SC 118389-1

MUNICÍPIO: Porto União

DATA: Abril/2021

DESENHO: Vinicius A. Makiak

ESCALA: indicada

ESTADO: Santa Catarina